

**Features**

- Epitaxial Planar Die Construction
- Complementary PNP Types Available (DDTB)
- Built-In Biasing Resistors, R1, R2
- **Lead, Halogen and Antimony Free, RoHS Compliant "Green" Device (Notes 2 and 3)**

**Mechanical Data**

- Case: SOT-23
- Case Material: Molded Plastic. UL Flammability Classification Rating 94V-0
- Moisture Sensitivity: Level 1 per J-STD-020D
- Terminal Connections: See Diagram
- Terminals: Solderable per MIL-STD-202, Method 208
- Lead Free Plating (Matte Tin Finish annealed over Alloy 42 leadframe).
- Marking Information: See Table Below & Page 3
- Ordering Information: See Page 3
- Weight: 0.008 grams (approximate)

P/N	R1 (NOM)	R2 (NOM)	MARKING
DDTD113EC	1K	1K	N60
DDTD123EC	2.2K	2.2K	N61
DDTD143EC	4.7K	4.7K	N62
DDTD114EC	10K	10K	N63
DDTD122JC	0.22K	4.7K	N64
DDTD113ZC	1K	10K	N65
DDTD123YC	2.2K	10K	N66
DDTD133HC	3.3K	10K	N67
DDTD123TC	2.2K	OPEN	N69
DDTD143TC	4.7K	OPEN	N70
DDTD114TC	10K	OPEN	N71
DDTD114GC	0	10K	N72

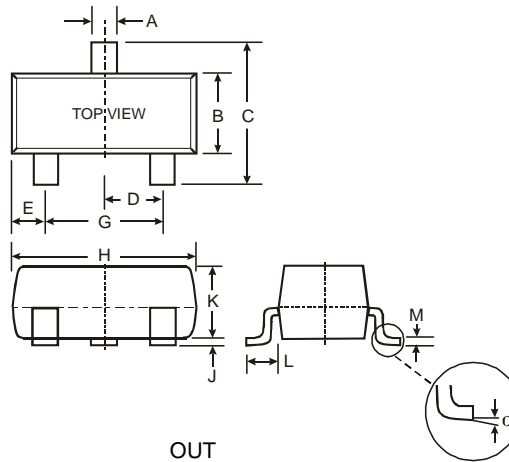

SOT-23		
Dim	Min	Max
A	0.37	0.51
B	1.20	1.40
C	2.30	2.50
D	0.89	1.03
E	0.45	0.60
G	1.78	2.05
H	2.80	3.00
J	0.013	0.10
K	0.903	1.10
L	0.45	0.61
M	0.085	0.110
$\alpha$	0°	8°

All Dimensions in mm

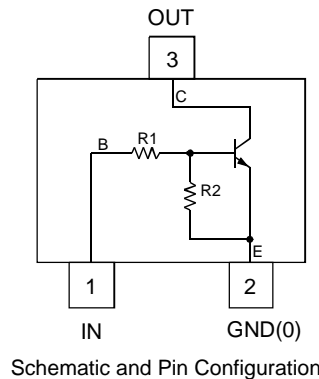

**Maximum Ratings** @T<sub>A</sub> = 25°C unless otherwise specified

Characteristic	Symbol	Value	Unit
Supply Voltage, (3) to (2)	V <sub>CC</sub>	50	V
Input Voltage, (1) to (2)	V <sub>IN</sub>	-10 to +10 -10 to +12 -10 to +30 -10 to +40 -5 to +5 -5 to +10 -5 to +12 -6 to +20	V
Input Voltage, (2) to (1)	V <sub>EBO (MAX)</sub>	5	V
Output Current	I <sub>C</sub>	500	mA
Power Dissipation	P <sub>D</sub>	200	mW
Thermal Resistance, Junction to Ambient Air (Note 1)	R <sub>θJA</sub>	625	°C/W
Operating and Storage Temperature Range	T <sub>J</sub> , T <sub>STG</sub>	-55 to +150	°C

- Notes:
1. Mounted on FR4 PC Board with recommended pad layout at <http://www.diodes.com/datasheets/ap02001.pdf>.
  2. No purposefully added lead. Halogen and Antimony Free.
  3. Product manufactured with Data Code V9 (week 33, 2008) and newer are built with Green Molding Compound. Product manufactured prior to Date Code V9 are built with Non-Green Molding Compound and may contain Halogens or Sb<sub>2</sub>O<sub>3</sub> Fire Retardants.

**Electrical Characteristics** @T<sub>A</sub> = 25°C unless otherwise specified

**R1, R2 Types**

Characteristic		Symbol	Min	Typ	Max	Unit	Test Condition
Input Voltage	DDTD113EC DDTD123EC DDTD143EC DDTD114EC DDTD122JC DDTD113ZC DDTD123YC DDTD133HC	V <sub>I(off)</sub>	0.5 0.5 0.5 0.5 0.5 0.3 0.3 0.3	—	—	V	V <sub>CC</sub> = 5V, I <sub>O</sub> = 100μA
	DDTD113EC DDTD123EC DDTD143EC DDTD114EC DDTD122JC DDTD113ZC DDTD123YC DDTD133HC	V <sub>I(on)</sub>	—	—	3.0 3.0 3.0 3.0 3.0 2.0 2.0 2.0	V	V <sub>O</sub> = 0.3V, I <sub>O</sub> = 20mA V <sub>O</sub> = 0.3V, I <sub>O</sub> = 20mA V <sub>O</sub> = 0.3V, I <sub>O</sub> = 20mA V <sub>O</sub> = 0.3V, I <sub>O</sub> = 10mA V <sub>O</sub> = 0.3V, I <sub>O</sub> = 30mA V <sub>O</sub> = 0.3V, I <sub>O</sub> = 20mA V <sub>O</sub> = 0.3V, I <sub>O</sub> = 20mA V <sub>O</sub> = 0.3V, I <sub>O</sub> = 20mA
Output Voltage		V <sub>O(on)</sub>	—	—	0.3V	V	I <sub>O</sub> /I <sub>I</sub> = -50mA/-2.5mA
Input Current	DDTD113EC DDTD123EC DDTD143EC DDTD114EC DDTD122JC DDTD113ZC DDTD123YC DDTD133HC	I <sub>I</sub>	—	—	7.2 3.8 1.8 0.88 28 7.2 3.6 2.4	mA	V <sub>I</sub> = 5V
Output Current		I <sub>O(off)</sub>	—	—	0.5	μA	V <sub>CC</sub> = 50V, V <sub>I</sub> = 0V
DC Current Gain	DDTD113EC DDTD123EC DDTD143EC DDTD114EC DDTD122JC DDTD113ZC DDTD123YC DDTD133HC	G <sub>I</sub>	33 39 47 56 47 56 56 56	—	—	—	V <sub>O</sub> = 5V, I <sub>O</sub> = 50mA
Input Resistor Tolerance		ΔR <sub>1</sub>	-30	—	+30	%	—
Resistance Ratio Tolerance		Δ(R <sub>2</sub> /R <sub>1</sub> )	-20	—	+20	%	—
Gain-Bandwidth Product*		f <sub>T</sub>	—	200	—	MHz	V <sub>CE</sub> = 10V, I <sub>E</sub> = 5mA, f = 100MHz

\* Transistor - For Reference Only

**Electrical Characteristics** @T<sub>A</sub> = 25°C unless otherwise specified

**R1 Only, R2 Only Types**

Characteristic		Symbol	Min	Typ	Max	Unit	Test Condition
Collector-Base Breakdown Voltage		BV <sub>CBO</sub>	50	—	—	V	I <sub>C</sub> = 50μA
Collector-Emitter Breakdown Voltage		BV <sub>CEO</sub>	40	—	—	V	I <sub>C</sub> = 1mA
Emitter-Base Breakdown Voltage	DDTD123TC DDTD143TC DDTD114TC DDTD114GC	BV <sub>EBO</sub>	5	—	—	V	I <sub>E</sub> = 50μA I <sub>E</sub> = 50μA I <sub>E</sub> = 50μA I <sub>E</sub> = 720μA
Collector Cutoff Current		I <sub>CBO</sub>	—	—	0.5	μA	V <sub>CB</sub> = 50V
Emitter Cutoff Current	DDTD123TC DDTD143TC DDTD114TC DDTD114GC	I <sub>EBO</sub>	— — — 300	—	0.5 0.5 0.5 580	μA	V <sub>EB</sub> = 4V
Collector-Emitter Saturation Voltage		V <sub>CE(sat)</sub>	—	—	0.3	V	I <sub>C</sub> = 50mA, I <sub>B</sub> = 2.5mA
DC Current Transfer Ratio	DDTD123TC DDTD143TC DDTD114TC DDTD114GC	h <sub>FE</sub>	100 100 100 56	250 250 250 —	600 600 600 —	—	I <sub>C</sub> = 5mA, V <sub>CE</sub> = 5V
Bias Resistor Tolerance		ΔR <sub>1</sub> or ΔR <sub>2</sub>	-30	—	+30	%	—
Gain-Bandwidth Product*		f <sub>T</sub>	—	200	—	MHz	V <sub>CE</sub> = 10V, I <sub>E</sub> = -5mA, f = 100MHz

\* Transistor - For Reference Only

## Ordering Information (Note 4)

Device	Packaging	Shipping
DDTD113EC-7-F	SOT-23	3000/Tape & Reel
DDTD123EC-7-F	SOT-23	3000/Tape & Reel
DDTD143EC-7-F	SOT-23	3000/Tape & Reel
DDTD114EC-7-F	SOT-23	3000/Tape & Reel
DDTD122JC-7-F	SOT-23	3000/Tape & Reel
DDTD113ZC-7-F	SOT-23	3000/Tape & Reel
DDTD123YC-7-F	SOT-23	3000/Tape & Reel
DDTD133HC-7-F	SOT-23	3000/Tape & Reel
DDTD123TC-7-F	SOT-23	3000/Tape & Reel
DDTD143TC-7-F	SOT-23	3000/Tape & Reel
DDTD114TC-7-F	SOT-23	3000/Tape & Reel
DDTD114GC-7-F	SOT-23	3000/Tape & Reel

Notes: 4. For packaging details, go to our website at <http://www.diodes.com/datasheets/ap02007.pdf>.

## Marking Information

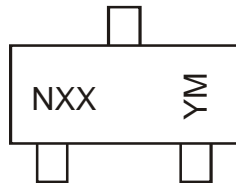

NXX = Product Type Marking Code, See Table on Page 1  
 YM = Date Code Marking  
 Y = Year ex: T = 2002  
 M = Month ex: 9 = September

### Date Code Key

Year	2002	2003	2004	2005	2006	2007	2008	2009	2010	2011	2012
Code	N	P	R	S	T	U	V	W	X	Y	Z

Month	Jan	Feb	Mar	Apr	May	Jun	Jul	Aug	Sep	Oct	Nov	Dec
Code	1	2	3	4	5	6	7	8	9	O	N	D

### IMPORTANT NOTICE

Diodes Incorporated and its subsidiaries reserve the right to make modifications, enhancements, improvements, corrections or other changes without further notice to any product herein. Diodes Incorporated does not assume any liability arising out of the application or use of any product described herein; neither does it convey any license under its patent rights, nor the rights of others. The user of products in such applications shall assume all risks of such use and will agree to hold Diodes Incorporated and all the companies whose products are represented on our website, harmless against all damages.

### LIFE SUPPORT

Diodes Incorporated products are not authorized for use as critical components in life support devices or systems without the expressed written approval of the President of Diodes Incorporated.